

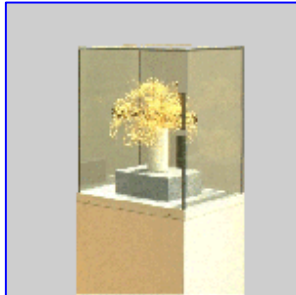

CLAM ~ Airtight Glass Showcases



CLAM-S



CLAM-LD



CLAM-HD

Click's CLAM bonded case systems are produced in custom sizes and provide fully bonded solutions using from 6.38mm to 13.5mm thick laminated glass. The frame element, which is selected based on the thickness of glass required, can then incorporate a lift-off lid, or a lid that is hinged in a variety of ways. CLAM-LD and CLAM-HD are fitted with gas strut action and use high security locking

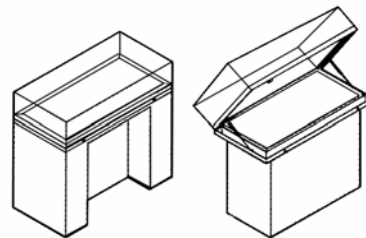
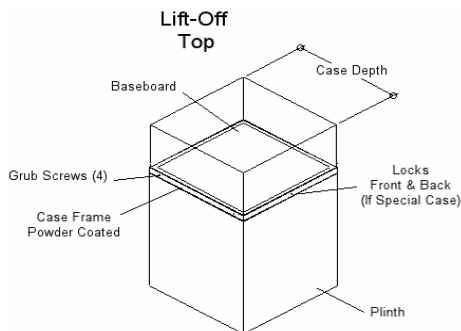

systems.

Any CLAM case may be wall or plinth mounted and used in any orientation.

The basic CLAM-S (Sealed Glass Box System) showcase provides moderate security with excellent environmental protection. Limited to 6.38mm laminated glass, the system provides minimum visual obstruction to the housed object. Access is by lifting the case top so sizes are limited. CLAM-LD uses 9.5mm laminated glass that meets full 'anti-bandit' specifications. The case provides a slimmer high security case than CLAM-HD at a lower cost. Gas strut supports are provided for horizontally mounted cases but the system is particularly suited to wall mounting with side hinged access. CLAM-HD, the 'heavy duty' CLAM case, provides the highest level of security in the range. Gas struts and Abloy locking systems are all standard on CLAM showcases. Specifications vary for each of the showcases in the CLAM range so please contact us for precise particulars.

If you require any further information please contact us on 1800 805 842 or visit our website at www.clicksystems.com.au

Click Systems Pty. Ltd. ABN 50 005 306 203
 130 Broderick Road Corio Vic 3214 - P.O. Box 210 Corio Vic 3214 - Ph 1800 805 842
 Email click@clicksystems.com.au or visit www.clicksystems.com.au