



Australia's Leading Provider of Museum Quality Showcase Solutions

Showcasing Australia for 30 Years



(VIP Hinge Showcase - National Wine Centre South Australia – photo courtesy of Classic Resources)

Click Systems has been developing system-based structures and showcases in Australia for over 25 years.

We specialise in servicing the Australian Museums and Galleries community and believe our range of showcases to be among the most versatile and technically advanced in the world. Over the years, Click has also produced many innovative product lines for shopfitting, office furniture, exhibition display, and lighting.

No matter where you are located in Australia every custodian of our history and heritage shares the common need to securely and cleanly store and display their collections in an appropriate and cost-effective fashion. At Click we recognise that the needs of this community can range widely from relatively simple background storage situations up to highly elaborate and complex environmentally controlled high-security display units.

Whatever you might need Click has the right solution for your circumstances - no matter how simple or complex Click are the only Australian manufacturer and supplier who can offer you the right choice from a comprehensive range of purpose-designed and cost-effective solutions. Recent developments have seen some exciting new products in our range and our website can be found at www.clicksystems.com.au.

If we can be of further service to you please contact us on 1800 805 842

Click Systems Pty. Ltd. ABN 50 005 306 203
130 Broderick Road Corio Vic 3214 - P.O. Box 210 Corio Vic 3214 - Ph 1800 805 842
Email click@clicksystems.com.au or visit www.clicksystems.com.au

A Proudly Australian Family-Owned Manufacturing Enterprise

CLICK SHOWCASES AT A GLANCE



QUADRANT ~ Completely compatible with the entire range of CLICK system products QUADRANT is a fully specified medium performance affordable showcase system available in radiused, chamfered or square sections. Lighting and sophisticated shelving and door systems are incorporated in the QUADRANT showcase system. Unusual in this type of system, QUADRANT is capable of accepting panels up to 13mm thick and glass up to 6.38mm laminated. This provides a far greater degree of strength and durability than any other comparable system.



GALLERY 20 ~ Our GALLERY 20 Showcase system has been developed to provide Museums, Galleries and Libraries with a state of the art display medium. The Gallery 20 range of showcases is specially designed for travelling exhibitions or as a budget solution for permanent displays where high visibility is important. The showcases can be readily assembled for a static display or broken down and reassembled many times for a travelling exhibition. GALLERY 20 showcases consist of fully framed panels using narrow interlocking natural anodised aluminium extrusions.



INCA ~ Our INCA showcases are produced in custom sizes and may be in single or multiple bays. Constructions vary from bonded glass top through demountable, rapid assembly or fully specified high security museum grade cases. INCA Bonded Glass Top Cases are suitable for single bay cases where the most minimal appearance is desired. Lighting is from outside the case or by the use of reflex FLEX fibre optics. Optional accessories include silica-gel systems for environment control, pendant or cantilever shelving, fluorescent, low voltage or fibre optic lighting and pull-and-slide or hinged doors. INCA Demountable Glass Top Cases are suitable for single or multiple bay cases where it is desired to be able to dismantle a glass topped case in the future.



MONO ~ Our MONO Casefront is a simple sealed hinged frame that provides both security and environmental protection. The frame is easily incorporated into metal or timber structures. The framed nature of the design makes the use of anti-reflective glass simple. MONO-3D takes this principle further joining two MONO Casefront frames with demountable rails and panels to form a complete case. MONO-3D are demountable framed cases suitable for single bay structures that need to be dismantled on a regular basis. Cases come standard with two doors fitted to opposing faces. The basic case is glass-topped but lighting can be incorporated.

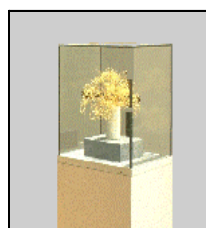

CLAM ~ Our CLAM-S Sealed Glass Box System provides moderate security with excellent environmental protection. Limited to 6.38mm laminated glass, the system provides minimum visual obstruction to the housed object. Access is by lifting the case top so sizes are limited. CLAM-LD uses 9.5mm laminated glass that meets full 'anti-bandit' specifications. The case provides a slimmer high security case than CLAM-HD at a lower cost. Gas strut supports are provided for horizontally mounted cases but the system is particularly suited to wall mounting with side hinged access. CLAM-HD, the 'heavy duty' CLAM case, provides the highest level of security in the range. Gas struts and Abloy locking are all standard.



QUDOS ~ QUDOS is our range of QUADRANT style Showcases with minimal visual obstructions to the front of the showcase. All styles can be customised to suit your needs. Lighting Options include Low Voltage Down Lights (with or without dimmer switches), Fluorescent and FLEX Fibre Optics. The most noticeable difference between QUDOS and our standard QUADRANT range of showcases is that QUDOS does not have any aluminium uprights to the front. Visually this showcase gives the feel that it is a frameless showcase designed for museums, shops and offices. The aluminium uprights at the back allow security to be maintained for either hinged or rolling doors in glass or solid panels and Click always recommends and uses Abloy security locks.

Click Systems Pty. Ltd. ABN 50 005 306 203
130 Broderick Road Corio Vic 3214 - P.O. Box 210 Corio Vic 3214 - Ph 1800 805 842
Email click@clicksystems.com.au or visit www.clicksystems.com.au

A Proudly Australian Family-Owned Manufacturing Enterprise



TETRAS ~ Showcasing Australia for 30 Years



(TetraS Images: Pacific Cultures Gallery at the South Australian Museum, the Museum of Australian Army Flying in Oakey QLD, Interpretational Display at Port Macquarie Government House NSW and the Changi Flag at the Shrine of Remembrance in Melbourne)

Click Systems has been developing system-based showcases in Australia for 30 years. We specialise in servicing the Australian Museums and Galleries community and believe our range of showcases to be among the most versatile and technically advanced in the world.

Our **NEW TETRAS** Showcase system is a demountable conservation grade modular showcase. Now your investment can be reconfigured from single to multi bay to suit your exhibition requirements. There are many styles available in our **TETRAS** showcase system these include free standing towers, wall mounted and table tops, which are fitted with hinged door and Abloy locks for added security.

To compliment our **TETRAS** Showcase system, we have a range of lighting and shelving options to suit all of your needs. We can also customise your exposed surfaces with a 2 pack auto grade paint finish of your choice.

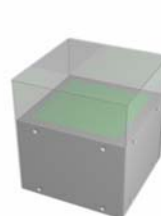

If you require any further information please contact us on 1800 805 842 or visit our website at www.clicksystems.com.au

Click Systems Pty. Ltd. ABN 50 005 306 203
130 Broderick Road Corio Vic 3214 - P.O. Box 210 Corio Vic 3214 - Ph 1800 805 842
Email click@clicksystems.com.au or visit www.clicksystems.com.au



Click Systems Pty Ltd

ABN 50 005 306 203

130 Broderick Road Corio Vic 3214

P.O. Box 210 Corio Vic 3214

Ph 03 5274 1133 Fax 03 5274 1199

click@clicksystems.com.au

www.clicksystems.com.au

PRE-LOVED SPECIALS

Ex "Sacred Vessels" Exhibition – Gippsland Art Gallery



- **TYPE 1 - SQ TGF 06D** - 2000 high x 600 wide x 600 deep @ **\$2,000.00** each
- **TYPE 2 - SQ TGF 12D** - 2000 high x 1200 wide x 600 deep @ **\$2,600.00** each

All standard features plus 3 shelves, 240 V down lights & 100mm high black kick plinth with concealed levelling feet

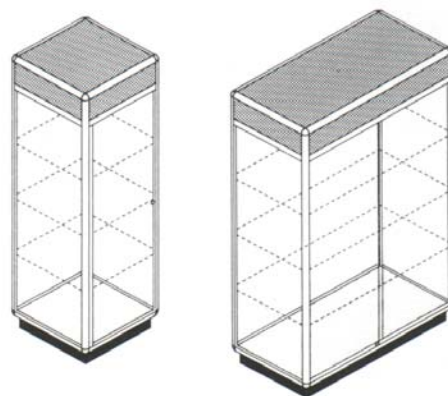

SQ TGF 06D SQ TGF 12D

Showcasing Australia for 30 years

Architectural & Cabinet Hardware – "If you can't find it we will"

A Proudly Australian Family-Owned Manufacturing Enterprise



- **TYPE3 - SQ MUT** - 900 mm high x 1200 mm wide x 600mm deep @ **\$1,400.00** each
- **TYPE 4 - SQ MUS** - 900 mm high x 900 mm wide x 900 mm deep @ **\$1,600.00** each
- Hinged lockable glass doors and recessed bases with no storage cupboard and concealed levelling feet

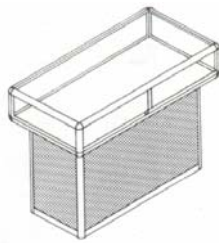

SQ MUT

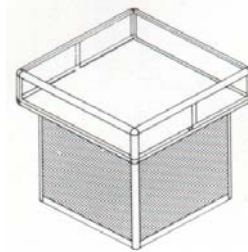

SQ MUS



ALL THESE EX SACRED VESSELS SHOWCASES HAVE THE FOLLOWING FINISHES: -

- Matt natural clear anodised aluminium QS “rounded” profile frames
- Lamiwood Oyster Grey pre finished board panels
- 6 mm clear float glass all exposed edges polished
- Abloy premium security locks that are keyed alike

TO THESE PRICES YOU WILL NEED TO ADD DELIVERY AND 10% GST

Showcasing Australia for 30 years

Architectural & Cabinet Hardware – “If you can’t find it we will”

A Proudly Australian Family-Owned Manufacturing Enterprise

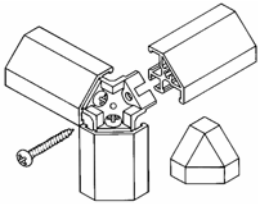

QUADRANT ~ Showcasing Australia for 30 Years



(Quadrant Images: 'Ned Kelly' at The Crown Casino for the Murdoch Address, Pharlap at the Victorian Museum and The Welcome Stranger Nugget at the Gold Treasury Museum)

Click Systems has been developing system-based showcases in Australia for 30 years. We specialise in servicing the Australian Museums and Galleries community and believe our range of showcases to be among the most versatile and technically advanced in the world.

Our **QUADRANT** range of purpose designed affordable showcases is completely compatible with the entire range of CLICK system products. Versatility in design and cost effectiveness make **QUADRANT** our most highly sought after showcase range. **QUADRANT'S** strong aluminium frame allows ease of access and enables the user to adapt the showcase to their own particular needs at a very reasonable cost.

QUADRANT is a fully specified medium performance showcase system available in radiused, chamfered or square sections. Lighting and sophisticated shelving and door systems are incorporated in the **QUADRANT** showcase system. Unusual for this level of showcase system **QUADRANT** is capable of accepting panels up to 13mm thick and glass up to 6.38mm laminated. This provides a far greater degree of strength, durability and security than any other comparable showcase system.

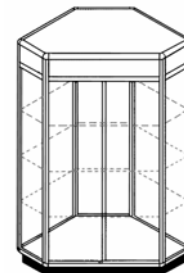
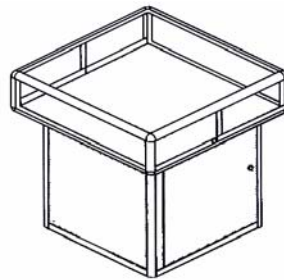
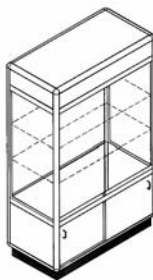

Whatever you might need Click has the right solution for your circumstances - no matter how simple or complex Click is the only Australian manufacturer and supplier who can offer you the right choice from a comprehensive range of purpose-designed and cost-effective solutions.

If you require any further information please contact us on 1800 805 842 or visit our website at www.clicksystems.com.au

Click Systems Pty. Ltd. ABN 50 005 306 203
130 Broderick Road Corio Vic 3214 - P.O. Box 210 Corio Vic 3214 - Ph 1800 805 842
Email click@clicksystems.com.au or visit www.clicksystems.com.au



Australia's Leading Provider of Museum Quality Showcase Solutions
Showcasing Australia for 30 Years
Quadrant Sections Available

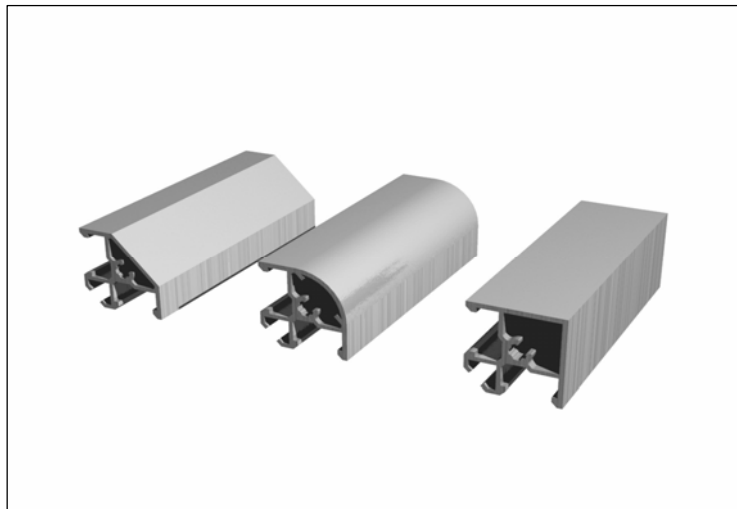

Sections Image ~ CQS, QS and SQS

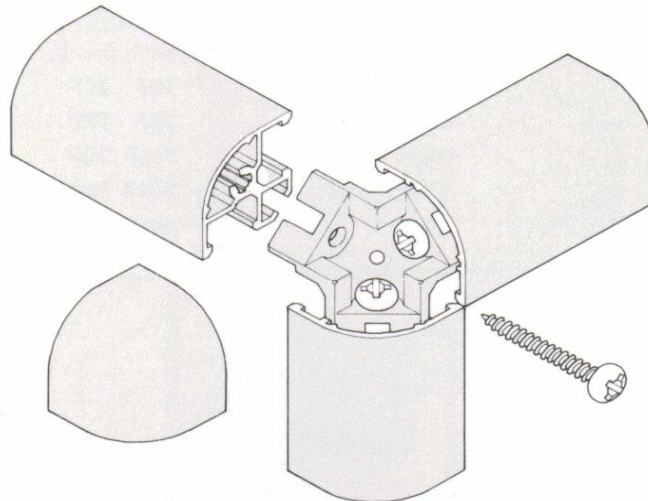

Example QS corner construction detail

Click Systems Pty. Ltd. ABN 50 005 306 203
130 Broderick Road Corio Vic 3214 - P.O. Box 210 Corio Vic 3214 - Ph 1800 805 842
Email click@clicksystems.com.au or visit www.clicksystems.com.au

A Proudly Australian Family-Owned Manufacturing Enterprise



The Australian Showcase & Hardware Company

[Home](#)

[Showcases](#)

[Projects](#)

[Hardware](#)

[Specials](#)

[Contact Us](#)

Museum Showcases – Display Cases – Architectural Hardware

The Australian Showcase & Hardware Company

Showcasing Australia for 30 Years

Click Systems is a family owned Australian manufacturing enterprise and Australia's leading provider of [Museum showcases](#) and [showcase solutions](#) to every State in Australia. Our clients include Australia's major Museums, Galleries and Libraries.

Click Systems have had many exciting years with the successful completion of a number of [major Museum and Library projects](#). Click [here](#) to see some photographs from these projects. Click [here](#) to download our [Products and Projects](#) PDF. (To view this file, you will need Adobe Acrobat Reader. This can be downloaded free from www.adobe.com)

Since 1977 we have been building Museum quality glass display cases and in 2000 we expanded our production capacity to incorporate an in-house hardware manufacturing plant. Since this time we have produced [HVP cabinet and architectural hardware](#) and we now manufacture over 200 glass, aluminium, brass, steel and [stainless steel products](#).

Click Systems are still offering many of the cases in our [Showroom at pre-loved prices](#). We locally manufacture a wide range of showcases to satisfy all of your display and conservation needs. Our [Quadrant](#), [Mono](#), [INCA-IV](#), [CLAM](#), [Gallery 20](#) and [NEW TetraS](#) Showcase systems are the Australian market leaders in their classes. Sample images of each system can be found in our [Showcase Galleries](#). Click [here](#) to download our [Showcasing Australia Brochure](#).

All of your [email enquiries](#) will be answered within 1 day or call us on **1800 805 842** from anywhere in Australia.

Last updated 24th May 2007



Visit our website www.clicksystems.com.au for more information